

# Center for Advanced High Magnetic Field Science



## Introduction

Experimental science leads to new findings through observation and ultimately drives universal principles and/or fundamentals. Materials science, which studies materials necessary for our daily life and modern industry, clarifies the electric, magnetic, mechanical, and thermodynamic properties of individual materials by investigating responses to the change in external parameters, such as electric field, magnetic field, pressure, and temperature. Therefore, a wide range of the external parameters, namely an enlarged observation window, sometimes brings about the discovery of new physical phenomena. It should be stressed that modern materials science has been grown by expanding the external parameter ranges. Magnetic field, which interacts directly with the spin degrees of freedom and orbital motions of electrons, is a soft and precisely controllable external parameter that characterizes the nature of materials. In the present Center, very high magnetic fields, which are not generated in most other laboratories, enable research on various kinds of materials. High magnetic fields do not only “investigate” the natures of materials, but also “change” them, and consequently provide observation of novel physical phenomena induced in very high magnetic fields. In addition, the experiments employ multiplexing of extreme conditions produced by very high pressure and extremely low temperatures. Research targets are magnetically frustrated systems, quantum

spin systems, and strongly correlated electron systems such as high-T<sub>c</sub> superconductors and heavy fermion systems. Focus on functional materials, like thermoelectric conversion elements, clarifies electronic states.

## Research Projects

The major research themes of this Center are:

1. Studies on magnetic field-induced quantum phases and phase transitions
2. High magnetic field studies on quantum criticality of strongly correlated electron systems
3. High magnetic field studies on functional materials
4. Development of experimental apparatus utilized under multiplexed extreme conditions.

## The History and Present Organization

The “High Magnetic Field Laboratory” was founded in 1980 by emeritus Professor Muneyuki Date as the high magnetic field facility of the Faculty of Science. In 1987, the Laboratory was reorganized as a division of the Research Center for Extreme Materials. The Center was subsequently reorganized twice, in 1996, as the “Research Center for Materials Science at Extreme

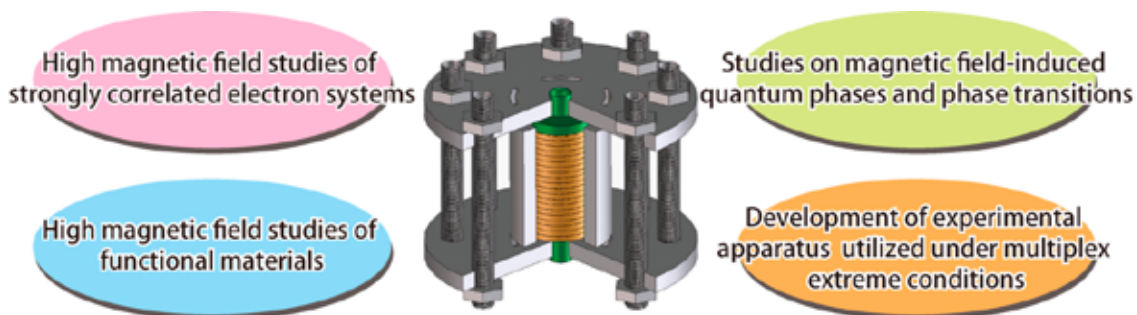

Research Themes and Cut-View of Pulse Magnet

Conditions”, and again in 2006, as the “Center for Quantum Science and Technology under Extreme Conditions”. From April 2014, the high magnetic field division in the last KYOKUGEN center started as a new center named “Center for Advanced High Magnetic Field Science” attached to Graduate School of Science.



Huge Capacitor Bank System



High Magnetic Field Joint-Usage Building and Center signboard

The Center consists of the following five divisions: “Research division of physics I”, “Research division of physics II”, “Research division of chemistry and biology”, “Research division of cooperation”, and “Support division for joint-usage”. The steering committee of the Center is operated by members elected from some departments in Graduate School of Science. The full-time members in the Center conduct research and education as a cooperative class and an undergraduate course in the Physics department.

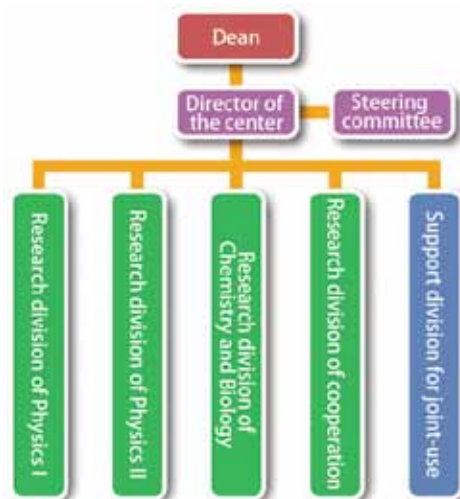

Center Organization Chart

### As a base of high-magnetic-field research

According to “High Magnetic Field Collaboraory (coined word: collaboration + laboratory) Plan” based on “Master Plan 2014” formulated by Science Council of Japan, the plan is to build a national joint-usage research base. As a first step, the steering committee of “Pulsed High Magnetic Field Collaboratory” was established by our center and International Megagauss Science Laboratory in the Institute for Solid State Physics, The University of Tokyo, and the national joint-usage research started from the fiscal year 2016. In addition, an agreement of cooperation and collaboration of high magnetic field research with research centers in Kobe and Fukui Universities (KOFUC network) was formalized on April 1, 2014. Academic exchanges and personnel training are conducted through these cooperation and collaboration.

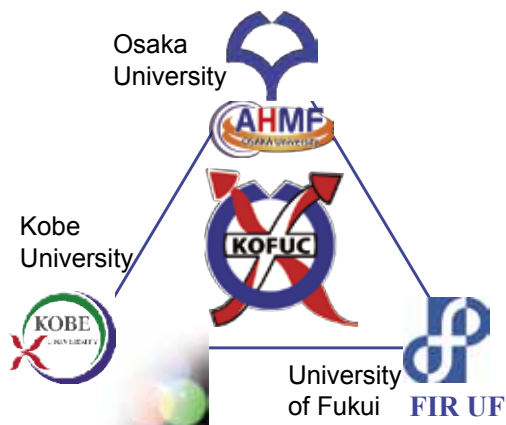

Three university centers and logo of KOFUC network